

# HOCHIKI

World Class Leaders in Fire Detection Since 1918

## FIREscape®

Intelligent, low-voltage,  
LED Emergency Lighting.



- Low Cost
- High Quality
- Low Maintenance
- Innovative Technology
- Lower Carbon Emissions

Your Safety, Our Technology

## COMPANY OVERVIEW

Hochiki is an independent, multi-national, publicly listed company with over 1500 employees across the globe. One of the world's leading manufacturers of commercial and industrial fire detection and emergency lighting solutions, Hochiki has acquired global acceptance as the benchmark for high-integrity and long-term reliability.

Hochiki's facilities in Japan, the United States of America and Europe design and manufacture products and provide technical support suited to local standards and customer requirements. Total commitment to meeting the needs of individual national markets has reinforced the company's global reputation, resulting in Hochiki products being installed in many prestigious sites and in over 80 countries worldwide.

## GLOBALLY PROVEN PRODUCT DESIGN

With Hochiki's vast expertise and heritage of cutting-edge design and technology, has developed **FIREscape**, the unique, highly cost effective and environmentally friendly emergency lighting system that incorporates the latest in LED and battery technologies. Designed, manufactured and tested in the UK, the system is based around an emergency lighting control panel with battery back-up and features addressable, self-contained luminaires and signage interconnected via traditional extra low-voltage cabling.

## STRUCTURE, COMPONENTS & OPERATION

Fully intelligent, the **FIREscape** system luminaires are fully monitored and incorporate a self-test facility, reassurance that the emergency lighting system is fully operational without the need for an individual inspection. With the option of being controlled manually or automatically, **FIREscape** can operate in either a maintained or non-maintained mode.

Luminaires attach directly onto a standard Hochiki Europe sensor base (YBN-R/3) with a simple "twist fit" operation, providing an emergency lighting solution that is quick and easy to install. To prevent unauthorised tampering after installation, the luminaire can be locked into its base, thereby preventing removal without the use of a special tool. Cabling and base units can be installed in the early stages of construction, followed by luminaires in the final phases in order to protect them from dirt and damage.

## CONTROL & MAINTENANCE

The **FIREscape** system is fully expandable and at its core is the addressable EL-2 control panel, up to 15 of which can be incorporated into a network. Each panel can accommodate up to two lines of devices, and up to 127 devices can be connected to each line, resulting in a potential system capacity of 3810 points.

The EL-2 control panel automatically monitors and tests the system's functionality on a continual basis. Information of completed tests is stored in the panel's memory and can be printed for end user records.

The discreet EL-KP keypad features an LCD graphic display and can show the address and location of activated or faulty devices.

Optional graphics software allows instant overview of the entire system and assists in maintenance tasks. Depicting the building in plan view and indicating alarm and fault states, **FIREscape** can be maintained from a central control room using this software.

**FIREscape** does not need 230 V wiring to individual luminaires – only extra low voltage cabling is required. Individual lighting sub-circuits are monitored at the local distribution board, simplifying installation. All **FIREscape** luminaires are equipped with integral batteries allowing continued operation for at least three hours, even where the control panel or line cables are damaged.

Backup battery power within each luminaire allows **FIREscape** lighting devices to use screened, non-fire rated cabling in lieu of heavy, costly fire resistant cabling. Coupled with extra low voltage operation, cabling costs are reduced by up to 60% compared with central battery based systems and up to 30% compared with other addressable self-contained systems.

Remote control of the EL-2 panel is also possible using a GSM alarm transfer unit, where fault data is transmitted to end user or service company GSM contacts.



EL-2



EL-KP

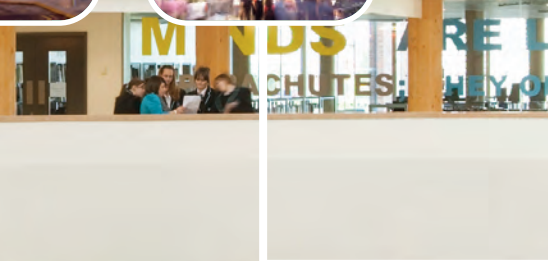
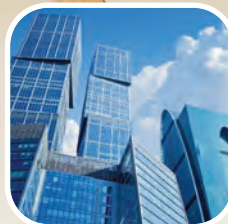

## KEY FEATURES

- ⚡ LED based
- ⚡ Intelligent addressable technology
- ⚡ Extra low voltage system
- ⚡ Self-contained lithium polymer auxiliary battery
- ⚡ Simple installation and unique plug in technology
- ⚡ Graphic software provides instant overview
- ⚡ Automatic monitoring and self-testing

## KEY BENEFITS

- ⚡ Cost saving - extra low voltage system
- ⚡ Environmentally friendly - low energy consumption and CO<sub>2</sub>e emissions
- ⚡ Labour saving – reduced installation and maintenance costs
- ⚡ Inherent reliability – minimum of 10 years system life expectancy (battery life expectancy is at least 5 years)



# FIREscape®

A UNIQUE

EMERGENCY LIGHTING SOLUTION THAT COULD SAVE UP TO  
£186,534 & OVER 26 TONNES OF CO<sub>2</sub>e OVER 10 YEARS\*

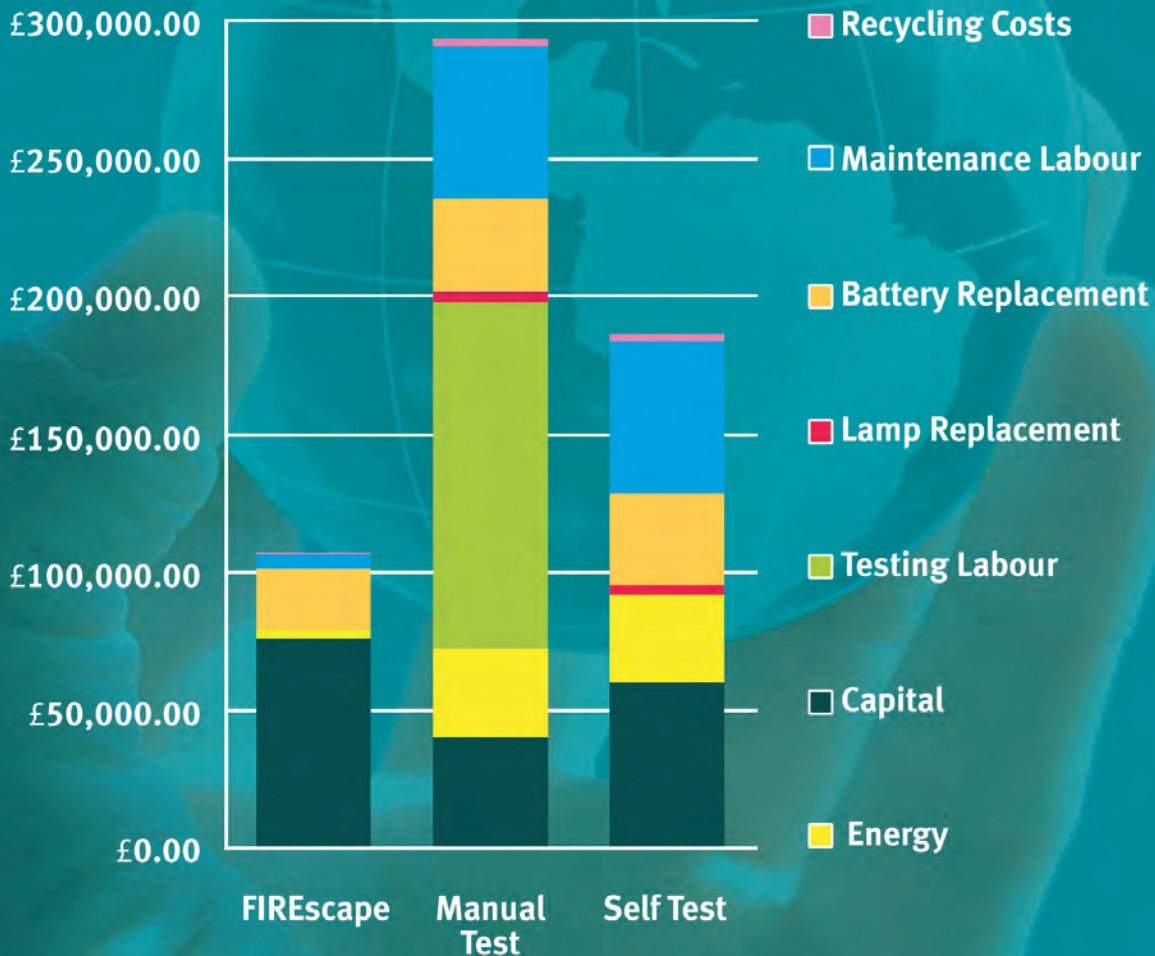

\*Based on a FIREscape system compared with a manual test system

## QUALITY & RELIABILITY

The **FIREscape** system complies with all British and European emergency lighting standards, in particular BS5266 for the design, manufacture and installation of emergency lighting systems. Hochiki Europe publishes a complimentary “Guide to BS5266” booklet, highlighting its commitment to the maintenance of quality and compliance within the industry.

## ENVIRONMENTAL CONSIDERATIONS – A GREEN SOLUTION TO EMERGENCY LIGHTING

The **FIREscape** solution considers the useful life of the entire emergency lighting system, from manufacture and installation, right through to recycling. Produced from fully recyclable materials, and incorporating LED technology that reduces CO<sub>2</sub>e emissions, **FIREscape** reduces its impact on the environment to an absolute minimum.

### EL-DL2

Corridor Down Light



### EL-DL3

Open Area Down Light



### EL-SL

Step Light

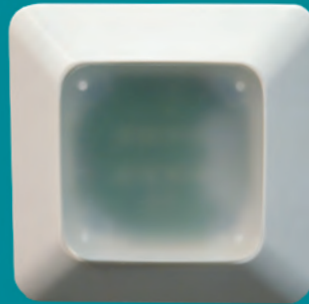

### EL-40D

40m Exit Sign (down arrow)



### EL-20D

20m Exit Sign (down arrow)

## REDUCED COST OF OWNERSHIP

**FIREscape** is simple to install, requires little maintenance or manual testing, and uses less than 5% energy consumption compared with conventional lighting.

Even at its peak lumen output, the LED draws only 80% of the recommended maximum energy level which minimises energy consumption and maximises LED lifespan.

Self-contained backup batteries negate the need for expensive fire-rated cabling, and in turn reduce the associated installation costs.

Each luminaire can be programmed to operate at any one of seven levels of light output, making them even more energy efficient when used as security or night-time lighting. They will automatically default to maximum light output should a failure in the 230 V supply be detected.



# SYSTEM ARCHITECTURE

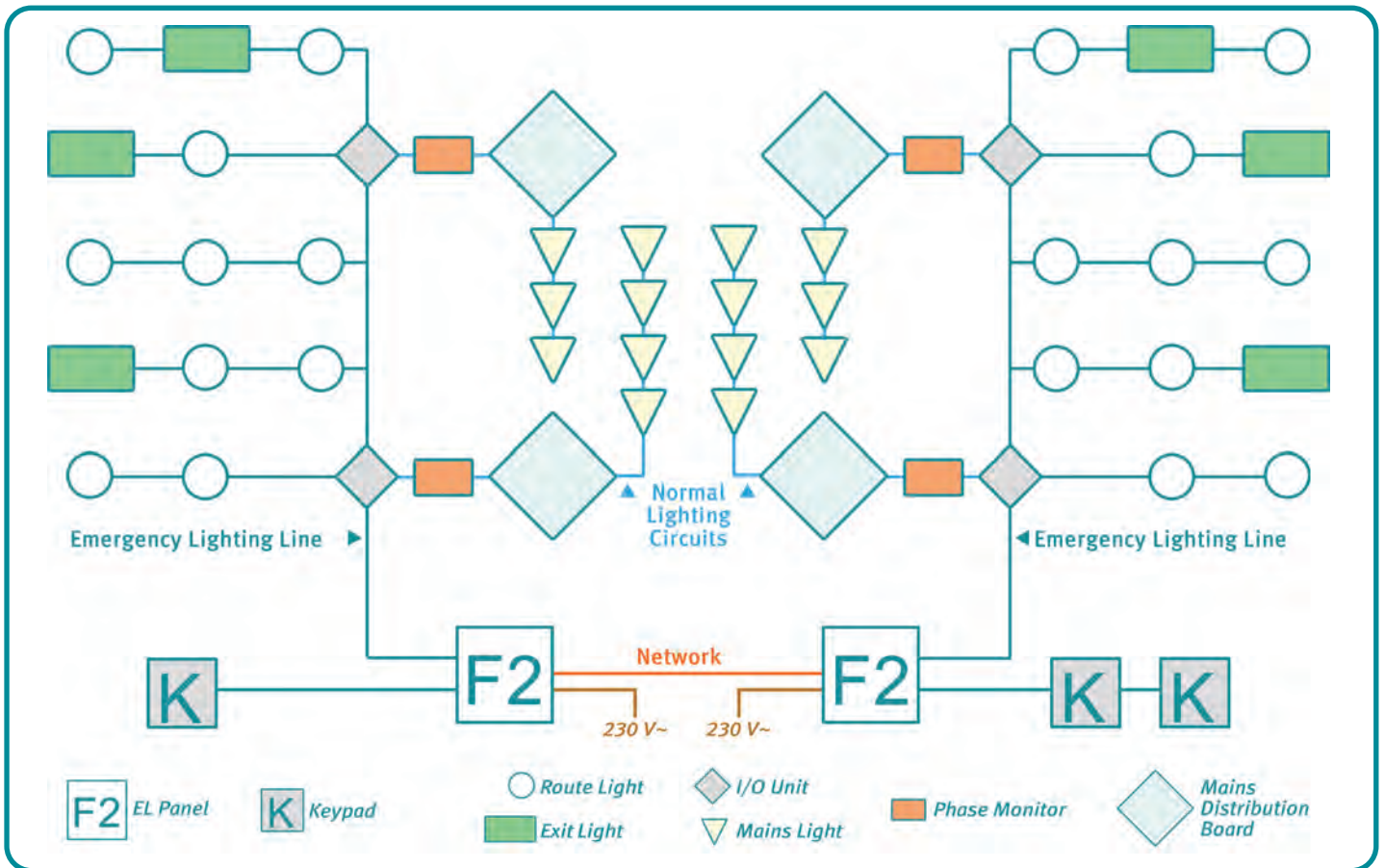

The diagram above shows a typical multi-panel **FIREscape** installation. The two EL-2 control panels are networked and these may be controlled by EL-KP keypads. The diagram illustrates how the system does not contain any mains wiring beyond (a) the EL-2 power supply and (b) the connection to the normal lighting circuit distribution board via the EL-PM Phase Monitor.



**HOCHIKI EUROPE (UK) LIMITED**  
 Grosvenor Road, Gillingham Business Park,  
 Gillingham, Kent, ME8 0SA, United Kingdom  
 Telephone: +44 (0)1634 260133  
 Facsimile: +44 (0)1634 260132  
 e-mail (UK Sales): sales@hochikieurope.com  
 e-mail (Non UK Sales): export@hochikieurope.com  
 www.hochikieurope.com  
 Reg. Address: 11 Raven Wharf, Lafone Street,  
 Butlers Wharf, London SE1 2LR  
 Registered in England no. 2639909  
 VAT no. GB 573 8188 03

**Your Safety, Our Technology**



Quality Systems Certificate  
 No. 164  
 Assessed to ISO 9001  
 Environmental Management  
 Certificate No. EMS 286  
 Assessed to ISO 14001

